

## Fire resistente tightening

A fire-resistant slab or wall loses its effectiveness due to the penetration of cable ducts or pipes. In case of fire, these penetrations constitute a privileged passage for flames and smoke. It is therefore appropriate to seal them tightly to fire.

The Pyro-safe Universal Tightening System allows you to divide a building into separate zones, separated from each other, which in technical terms is called a "subdivision"; this constituting the ideal solution to the types of problems mentioned above.

### Installation method

- Coat the thick side of the wall opening, cables, pipe passages, with the paint.
- Cut the panel to fit the hole and mount it so that it remains stalled.
- Close joints and opening with pieces of rockwool and dough/paste.
- Put a 1 mm thick top coat. on the panel, cables and pipes on both sides.
- Length for cables and pipes max. 200 mm.
- Provide an additional rock wool collar (previously treated) for larger pipes and
- possibly protect PE pipes. with a cuff (see technical sheet).

### Storage

- Store out of frost
- Stor no more than four buckets on top of each other
- The buckers, unopened can be kept at room temperature +/- 1 year
- The panel used in combination with the paint and pasta has been according to EN-1366-3, classification EN 13501-1 ET en-13501-2

Paint and pasta : 23,73€/Kilo - conditioned in bucket of 5Kg

Panel Ei 60' 1000mm x 600mm : 92,98€



## Cable tray through a wall

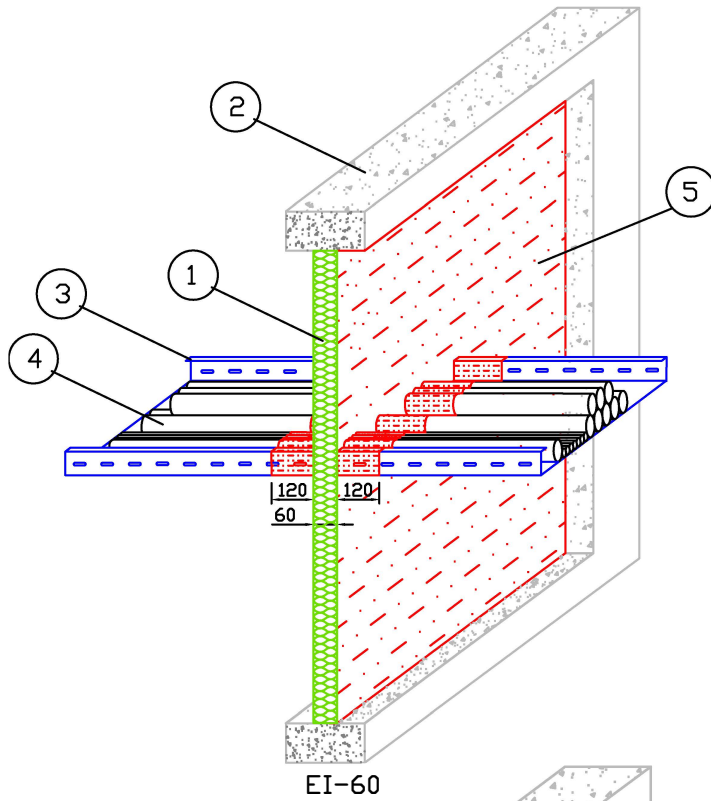

- 1-Laine de roche, ép=60mm  
Masse volumique = +/- 150 Kg/m<sup>3</sup>
- 2-Mur Rf
- 3-chemin de câbles
- 4-câbles
- 5-Peinture intumescente

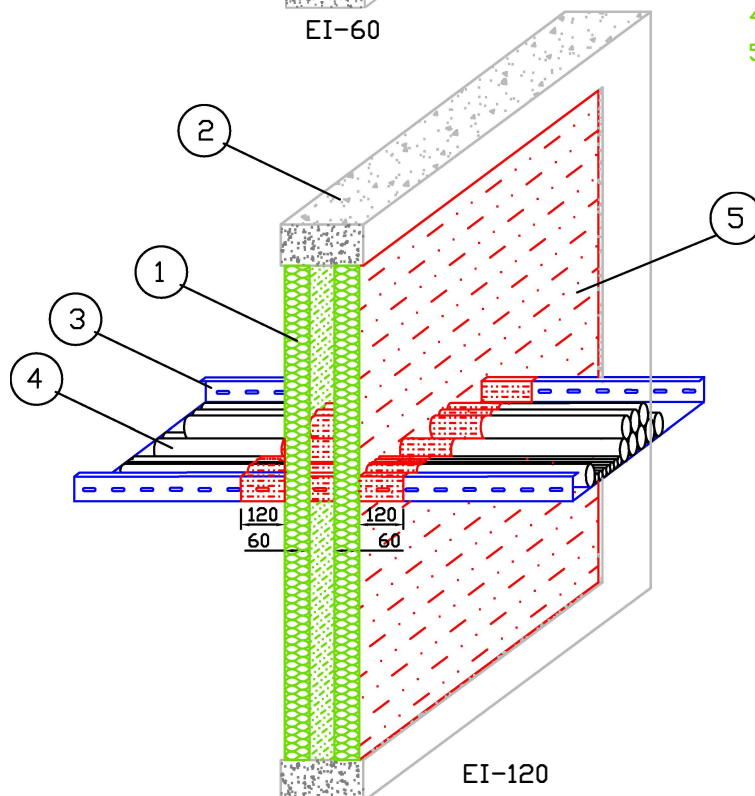

## Cable tray through a slab

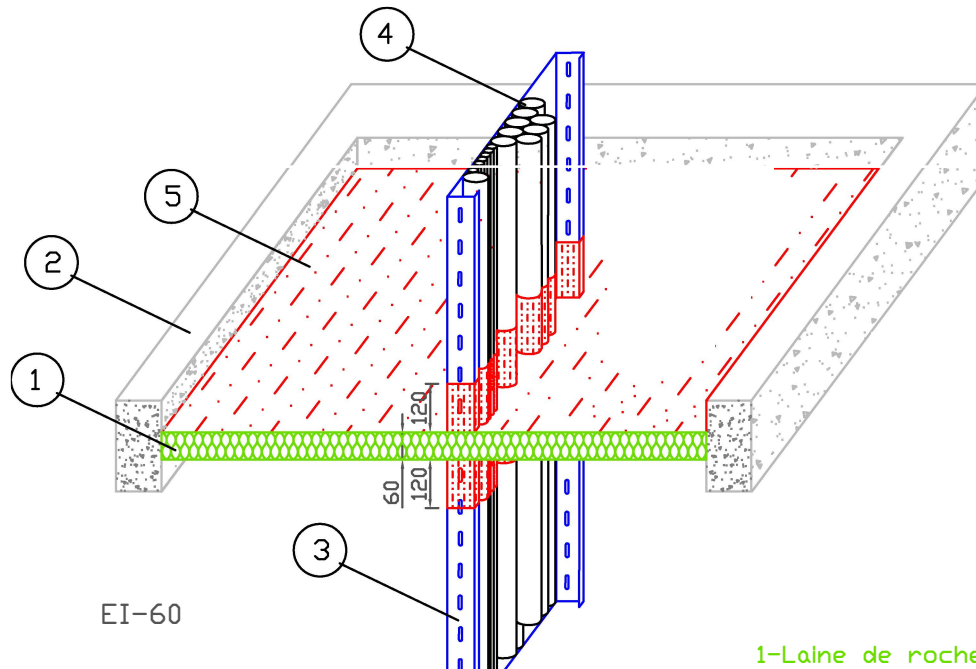

- 1-Laine de roche, e=60mm  
Masse volumique= +/- 150 Kg/m<sup>3</sup>
- 2-Dalle Rf
- 3-chemin de câbles
- 4- câbles
- 5-Peinture intumescente

